

FORMULAS FOR REFERENCE

SPHERE	Surface area	=	$4\pi r^2$
	Volume	=	$\frac{4}{3}\pi r^3$
CYLINDER	Area of curved surface	=	$2\pi rh$
	Volume	=	$\pi r^2 h$
CONE	Area of curved surface	=	πrl
	Volume	=	$\frac{1}{3}\pi r^2 h$
PRISM	Volume	=	base area \times height
PYRAMID	Volume	=	$\frac{1}{3} \times$ base area \times height

There are 36 questions in Section A and 18 questions in Section B.
The diagrams in this paper are not necessarily drawn to scale.

Section A

1. If $a = 2 - \frac{1}{1+b}$, then $b =$

A. $\frac{1-a}{a-2}$

B. $\frac{a-1}{a-2}$

C. $\frac{a+1}{a-2}$

D. $\frac{-a-3}{a-2}$

E. $\frac{1-a}{a}$

2. $(2x^2 - 3x + 1)(2 - 3x) =$

A. $6x^3 - 5x^2 - 3x + 2$

B. $6x^3 - 13x^2 - 9x - 2$

C. $-6x^3 + 13x^2 - 9x + 2$

D. $-6x^3 - 5x^2 - 3x + 2$

E. $-6x^3 - 5x^2 - 9x + 2$

3. Let $f(x) = (2x-1)(x+1) + 2x+1$. Find the remainder when $f(x)$ is divided by $2x+1$.

- A. -1
- B. $-\frac{1}{2}$
- C. 0
- D. 1
- E. 2

4. The figure shows a right-angled triangle where $AB:BC = 3:4$. Find $\sin \theta$.

- A. $\frac{5}{3}$
- B. $\frac{3}{4}$
- C. $\frac{5}{4}$
- D. $\frac{3}{5}$
- E. $\frac{4}{5}$

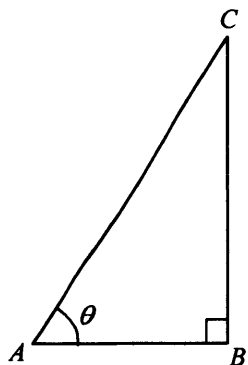

5. The bar chart below shows the distribution of scores in a test. Find the percentage of scores which are less than 3.

- A. 35%
- B. 40%
- C. 50%
- D. 65%
- E. 70%

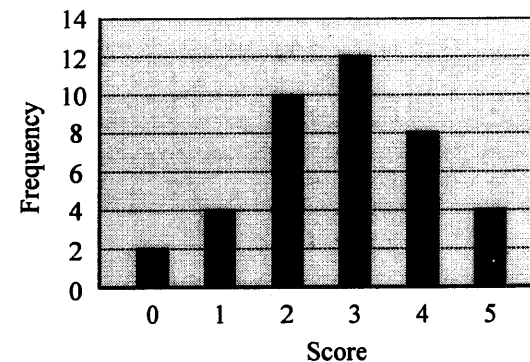

6. If the straight lines $2x-3y+1=0$ and $5x+ky-1=0$ are perpendicular to each other, find k .

- A. $-\frac{15}{2}$
- B. $-\frac{10}{3}$
- C. $\frac{3}{10}$
- D. $\frac{10}{3}$
- E. $\frac{15}{2}$

7. In the figure, find x correct to 3 significant figures.

- A. 2.65
- B. 2.79
- C. 3.16
- D. 4.00
- E. 4.36

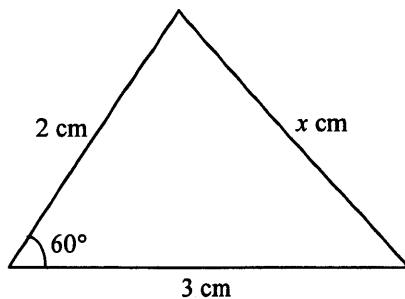

8. In the figure, the solid consists of a cylinder and a hemisphere with a common base of radius 6 cm. Find the total surface area of the solid.

- A. $132\pi \text{ cm}^2$
- B. $168\pi \text{ cm}^2$
- C. $204\pi \text{ cm}^2$
- D. $240\pi \text{ cm}^2$
- E. $324\pi \text{ cm}^2$

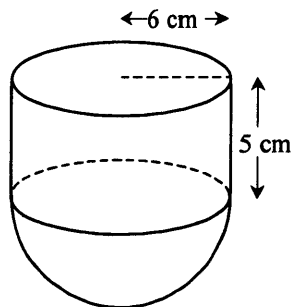

9. The figure shows a regular pentagon. Find its area correct to the nearest 0.01 cm^2 .

- A. 3.63 cm^2
- B. 5.88 cm^2
- C. 6.18 cm^2
- D. 6.88 cm^2
- E. 8.51 cm^2

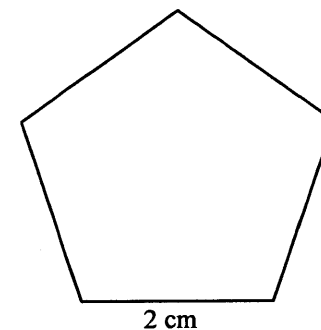

10. $\frac{a^{n-2} + a^{n-1}}{a^{n-2}} =$

- A. a^{n-1}
- B. $a^{n-2}(1+a)$
- C. $1+a^{n-1}$
- D. $1+\frac{1}{a}$
- E. $1+a$

11. Which of the following is an identity / are identities?

I. $x^2 + 2x + 1 = 0$

II. $x^2 + 2x + 1 = (x + 1)^2$

III. $x^2 + 1 > 0$

- A. I only
- B. II only
- C. III only
- D. I and III only
- E. II and III only

12. If $\begin{cases} y = x^2 - 4x - 44 \\ y = -2x + 4 \end{cases}$, then $y =$

- A. -32 or 52.
- B. -12 or 16.
- C. -12 or 96.
- D. -8 or 20.
- E. 12 or 24.

13. A piece of wire of length 36 cm is cut into two parts. One part, x cm long, is bent into a square and the other part is bent into a circle. If the length of a side of the square is equal to the radius of the circle, which of the following equations can be used to find x ?

A. $x = \frac{36 - 4x}{2\pi}$

B. $x = \frac{36 - x}{2\pi}$

C. $\frac{x}{4} = \frac{36 - 4x}{2\pi}$

D. $\frac{x}{4} = \frac{36 - x}{\pi}$

E. $\frac{x}{4} = \frac{36 - x}{2\pi}$

14. The sum of the first n terms of an arithmetic sequence is n^2 . Find the 10th term of the sequence.

- A. 19
- B. 21
- C. 28
- D. 31
- E. 100

15. The n th term of a geometric sequence is $-\frac{1}{2^n}$. Find the first term and the common ratio.

	<u>first term</u>	<u>common ratio</u>
A.	-1	$\frac{1}{2}$
B.	$-\frac{1}{2}$	$-\frac{1}{2}$
C.	$-\frac{1}{2}$	$\frac{1}{2}$
D.	$-\frac{1}{2}$	1
E.	1	$-\frac{1}{2}$

16. A bank offers loans at an interest rate of 18% per annum, compounded monthly. A man took a loan of \$20 000 and repays the bank in monthly instalments of \$4 000. Find the outstanding balance after his first instalment.

- A. \$16 000
 B. \$16 240
 C. \$16 300
 D. \$18 880
 E. \$19 600

17. If $0^\circ < x < y < 90^\circ$, which of the following must be true?

- I. $\sin x < \sin y$
 II. $\cos x < \cos y$
 III. $\sin x < \cos y$

- A. I only
 B. II only
 C. I and II only
 D. I and III only
 E. II and III only

18. In the figure, AEC is a diameter and DEB is a straight line. Find x .

- A. 54°
 B. 70°
 C. 74°
 D. 92°
 E. 94°

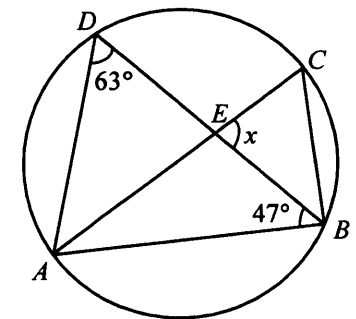

19. Which of the following pairs of triangles is/are similar?

I.

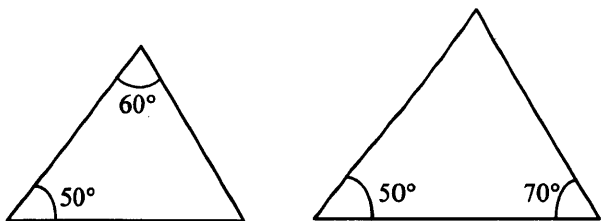

II.

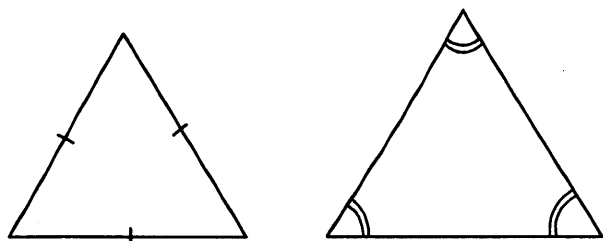

III.

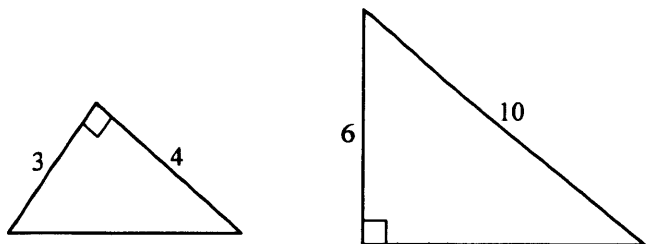

- A. II only
- B. III only
- C. I and II only
- D. I and III only
- E. I, II and III

20. In the figure, $x =$

- A. 50° .
- B. 55° .
- C. 60° .
- D. 65° .
- E. 70° .

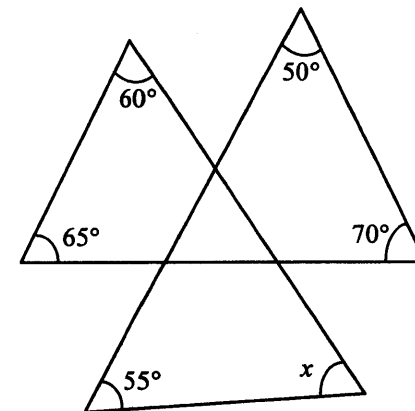

21. If the mean of the ten numbers 8, 6, 6, 6, 7, 4, 10, 9, 9, x is 7, find the median of the ten numbers.

- A. 5.5
- B. 6
- C. 6.5
- D. 7
- E. 7.5

22. Which of the following is a factor of $2(a-b)^2 - a^2 + b^2$?

- A. $a - 3b$
- B. $a - 2b$
- C. $a + b$
- D. $a + 3b$
- E. $3a - b$

23. In the figure, the graph of $y = 2x^2 - 9x + 4$ cuts the x -axis at A and B , and the y -axis at C . Find the area of $\triangle ABC$.

- A. 4
- B. 6
- C. 7
- D. 8
- E. 14

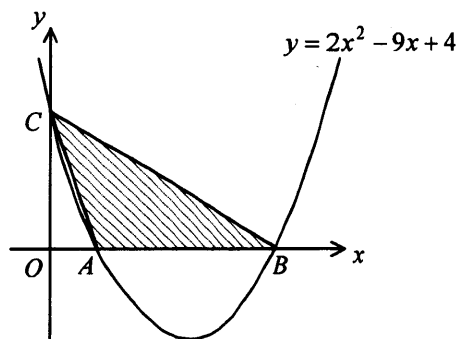

24. In the figure, a solid right circular cone of height 12 cm is put into a cylinder which has the same internal radius as the base radius of the cone. Water is then poured into the cylinder until the water level just reaches the tip of the cone. If the cone is removed, what is the height of the water in the cylinder?

- A. 3 cm
- B. 4 cm
- C. 6 cm
- D. 8 cm
- E. 9 cm

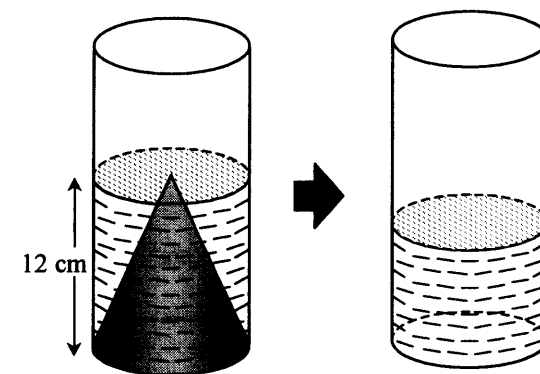

25. In the figure, $OABC$ is a sector. Find the length of the arc ABC .

- A. $\frac{2\pi}{3}$ cm
- B. 4π cm
- C. 5π cm
- D. 6π cm
- E. 12π cm

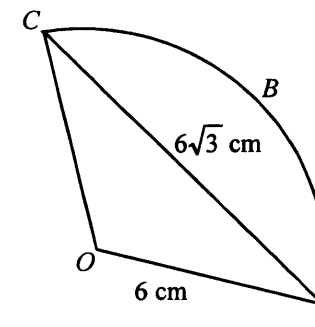

26. In the figure, A , B and C are the centres of three equal circles, each of radius 1 cm. Find the area of the shaded region.

- A. $\left(\frac{\pi}{2} - \frac{\sqrt{3}}{2}\right) \text{ cm}^2$
 B. $\left(\frac{\pi}{2} - \frac{3\sqrt{3}}{4}\right) \text{ cm}^2$
 C. $\left(\frac{\pi}{2} + \frac{\sqrt{3}}{4}\right) \text{ cm}^2$
 D. $\frac{\pi}{2} \text{ cm}^2$
 E. $\left(\frac{\pi}{2} - \frac{\sqrt{3}}{4}\right) \text{ cm}^2$

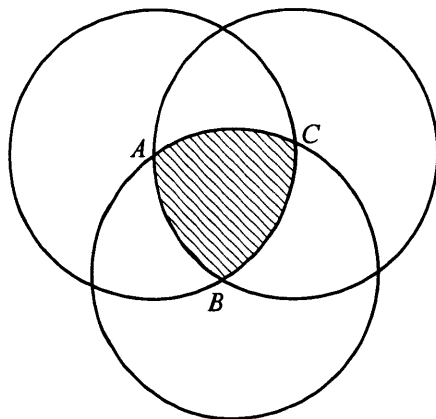

27. 40% of the students in a class failed in a test. They had to sit for another test in which 70% of them failed again. Find the percentage of students who failed in both tests.

- A. 10%
 B. 12%
 C. 18%
 D. 28%
 E. 30%

28. If $\frac{x+3y}{2x-y} = \frac{2}{3}$, then $\frac{x-y}{x+y} =$

- A. $-\frac{5}{6}$.
 B. $-\frac{3}{5}$.
 C. $\frac{3}{5}$.
 D. $\frac{3}{4}$.
 E. $\frac{5}{6}$.

29. Suppose y is partly constant and partly varies inversely as x . When $x=1$, $y=7$ and when $x=3$, $y=3$. Find y when $x=2$.

- A. 2.5
 B. 3.5
 C. 4
 D. 5
 E. 6.5

30. In the figure, find x correct to 3 significant figures.

- A. 8.86
- B. 9.34
- C. 9.48
- D. 10.7
- E. 11.3

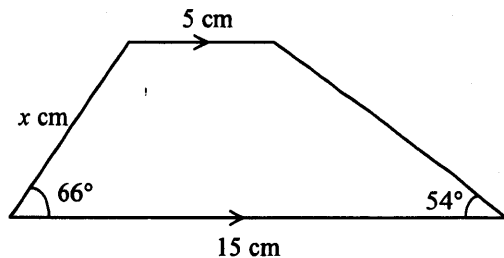

31. Ship A is 8 km due north of a light house L and ship B is 6 km due east of L . Find the bearing of B from A .

- A. N53.1°W (correct to the nearest 0.1°)
- B. N36.9°W (correct to the nearest 0.1°)
- C. N36.9°E (correct to the nearest 0.1°)
- D. S53.1°E (correct to the nearest 0.1°)
- E. S36.9°E (correct to the nearest 0.1°)

32. In the figure, $ABCD$ is a semicircle, $AB : BD = 4 : 3$. Find AB correct to the nearest 0.1 cm.

- A. 5.7 cm
- B. 7.6 cm
- C. 10.7 cm
- D. 13.0 cm
- E. 14.3 cm

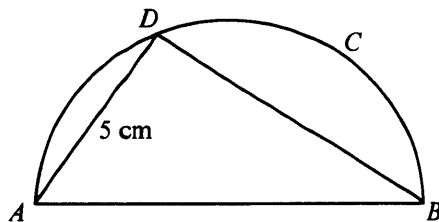

33. If the straight lines $x - 2y + 5 = 0$ and $ax - y + 1 = 0$ intersect at $(1, b)$, find a and b .

- A. $a = -4, b = -3$
- B. $a = -1, b = 0$
- C. $a = 1, b = 3$
- D. $a = 2, b = -3$
- E. $a = 2, b = 3$

34. In the figure, A, B and C are points on a rectangular coordinate plane. AC and BC are parallel to the x -axis and y -axis respectively. If the coordinates of C are $(2, 1)$ and the equation of the straight line AB is $y = 2x + 3$, find the distance between A and B .

- A. $\sqrt{5}$
- B. $\frac{3\sqrt{5}}{2}$
- C. $\sqrt{37}$
- D. $3\sqrt{5}$
- E. $\sqrt{65}$

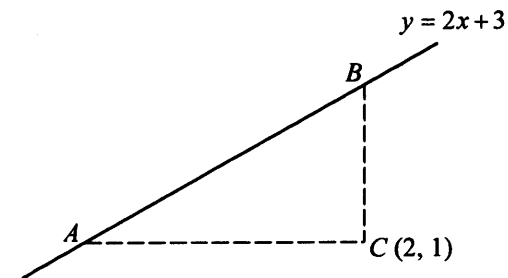

35. Two cards are drawn randomly from five cards numbered 1, 2, 3, 4 and 4 respectively. Find the probability that the sum of the two numbers drawn is even.

- A. $\frac{1}{2}$
B. $\frac{2}{5}$
C. $\frac{3}{10}$
D. $\frac{7}{10}$
E. $\frac{13}{25}$

36. A bag contains 2 black balls and 3 white balls. A boy randomly draws balls from the bag one at a time (without replacement) until a white ball appears. Find the probability that he will make at least 2 draws.

- A. $\frac{2}{5}$
B. $\frac{3}{5}$
C. $\frac{1}{10}$
D. $\frac{3}{10}$
E. $\frac{7}{10}$

Section B

37. If $\log x^2 = (\log x)^2$, then $x =$

- A. 1.
B. 10.
C. 100.
D. 1 or 10.
E. 1 or 100.

38. If $a > b$, which of the following must be true?

- I. $-a < -b$
II. $a + b > b$
III. $a^2 > b^2$

- A. I only
B. II only
C. III only
D. I and II only
E. I, II and III

39. If a, b are distinct real numbers and $\begin{cases} a^2 + 4a + 1 = 0 \\ b^2 + 4b + 1 = 0 \end{cases}$, find $a^2 + b^2$.

- A. 1
- B. 9
- C. 14
- D. 16
- E. 18

40. Suppose the graph of $y = x^2 - 2x - 3$ is given. In order to solve the quadratic equation $2x^2 - 6x - 3 = 0$, which of the following straight lines should be added to the given graph?

- A. $y = 4x$
- B. $y = x - \frac{3}{2}$
- C. $y = -x + \frac{3}{2}$
- D. $y = 2x - 3$
- E. $y = -2x + 3$

41. Find the mean deviation of the five numbers 0, 3, 4, 6 and 7.

- A. 0
- B. $\frac{3}{2}$
- C. $\frac{\sqrt{10}}{2}$
- D. 2
- E. $\sqrt{6}$

42. For $0^\circ \leq x \leq 360^\circ$, how many roots does the equation $\cos^3 x = \cos x$ have?

- A. 2
- B. 3
- C. 4
- D. 5
- E. 6

43. If $\tan(90^\circ - \theta) = 2$, then $\frac{\sin^3 \theta + \sin \theta \cos^2 \theta}{\cos \theta} =$

- A. 2.
- B. $\frac{1}{2}$.
- C. $\frac{1}{\sqrt{5}}$.
- D. $-\frac{1}{2}$.
- E. -2.

44. The figure shows the graph of the function

- A. $y = \sin \frac{x}{2}$.
- B. $y = 2 \sin x$.
- C. $y = 1 + \sin x$.
- D. $y = 1 + \cos x$.
- E. $y = 1 - \cos x$.

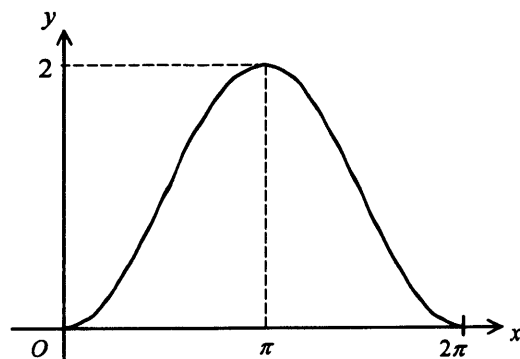

45. In the figure, O is the centre of the circle, AOB is a straight line and BCD is the tangent to the circle at C . Find x .

- A. 50°
- B. 53°
- C. 56°
- D. 59°
- E. 62°

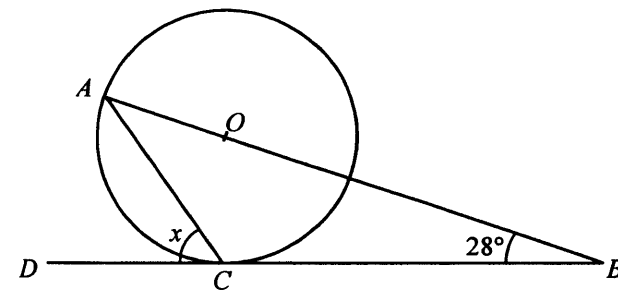

46. In the figure, $\widehat{AB} = \widehat{BC} = \frac{1}{2} \widehat{CD}$. Find $\angle ABC$.

- A. 100°
- B. 105°
- C. 112.5°
- D. 130°
- E. 150°

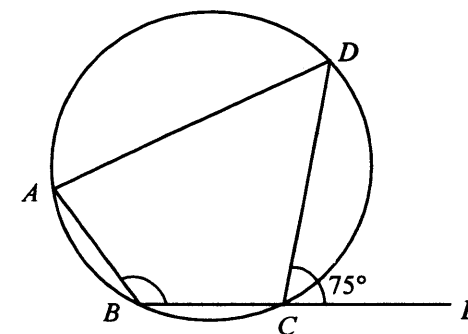

47. $\frac{1-x}{x^2+4x-5} + \frac{x-1}{x+1} =$

A. $\frac{x^2+3x-6}{(x+1)(x+5)}$

B. $\frac{x^2+5x-4}{(x+1)(x+5)}$

C. $\frac{(x+4)(x-1)}{(x+1)(x+5)}$

D. $\frac{(x-1)(x-4)}{(x+1)(x-5)}$

E. $\frac{(x-1)(x-6)}{(x+1)(x-5)}$

48. Let $f(x) = x^3 + 2x^2 + ax + b$. If $f(x)$ is divisible by $x+1$ and $x-2$, $f(x)$ can be factorized as

A. $(x-1)(x+1)(x-2)$

B. $(x+1)^2(x-2)$

C. $(x-3)(x+1)(x-2)$

D. $(x+3)(x+1)(x-2)$

E. $x(x+1)(x-2)$

49. The shaded region in the figure represents the solution of one of the following systems of inequalities. Which is it?

A. $\begin{cases} 2x-y \leq 0 \\ x+y \leq 6 \\ x \geq 0 \end{cases}$

B. $\begin{cases} 2x-y \leq 0 \\ x+y \leq 6 \\ y \geq 0 \end{cases}$

C. $\begin{cases} 2x-y \geq 0 \\ x+y \geq 6 \\ y \geq 0 \end{cases}$

D. $\begin{cases} 2x-y \geq 0 \\ x+y \leq 6 \\ y \geq 0 \end{cases}$

E. $\begin{cases} 2x-y \geq 0 \\ x+y \geq 6 \\ x \geq 0 \end{cases}$

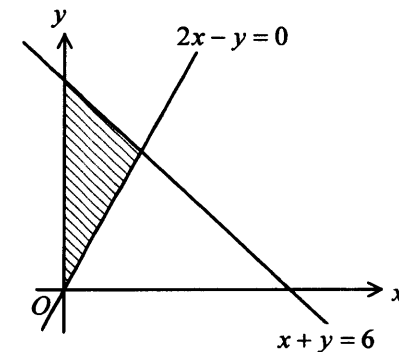

50. In the figure, ADB , BEC and CFA are straight lines. If the area of $\triangle ABC$ is 225 cm^2 , find the area of the parallelogram $DECF$.

- A. 81 cm^2
 B. 108 cm^2
 C. 126 cm^2
 D. 135 cm^2
 E. 162 cm^2

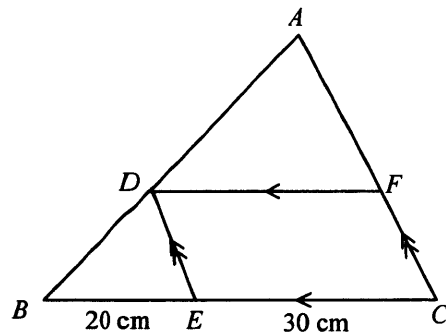

51. In the figure, PC is a vertical pole standing on the horizontal ground ABC . D is a point on line AB . If $\angle BCA = \angle CDB = 90^\circ$, $AC = 3 \text{ m}$, $BC = 4 \text{ m}$ and $PC = 5 \text{ m}$, find $\tan \theta$.

- A. $\frac{12}{25}$
 B. $\frac{16}{25}$
 C. $\frac{25}{16}$
 D. $\frac{25}{12}$
 E. $\frac{25}{9}$

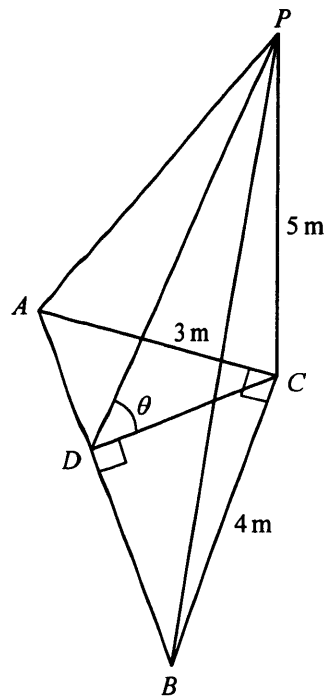

52. In the figure, $ABCD$ and $AGFE$ are straight lines. Find CF .

- A. 4 cm
 B. 3 cm
 C. $\frac{7}{2} \text{ cm}$
 D. $\frac{5}{2} \text{ cm}$
 E. $\frac{7}{3} \text{ cm}$

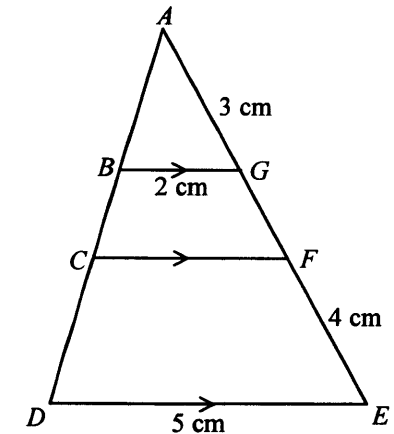

53. Consider the circle $x^2 + y^2 - 8x - 6y + 21 = 0$. Find the equation of the chord whose mid-point is $(5, 2)$.

- A. $9x + 5y - 55 = 0$
 B. $3x + 4y - 23 = 0$
 C. $x + y - 7 = 0$
 D. $x - y + 3 = 0$
 E. $x - y - 3 = 0$

54. In the figure, the inscribed circle of $\triangle OPQ$ touches PQ at R . Find the coordinates of R .

A. $\left(\frac{3}{2}, 2\right)$

B. $\left(\frac{6}{5}, \frac{12}{5}\right)$

C. $\left(\frac{9}{5}, \frac{8}{5}\right)$

D. $\left(\frac{9}{7}, \frac{16}{7}\right)$

E. $\left(\frac{12}{7}, \frac{12}{7}\right)$

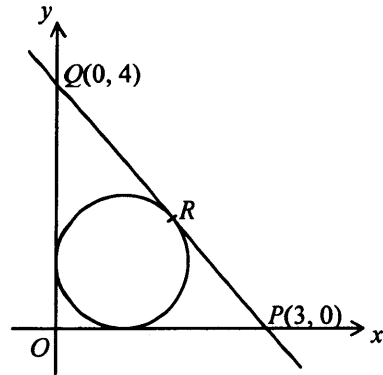

END OF PAPER